

Reliable®

Model F1FR QREC Series K8.0 (115 metric) Quick Response Extended Coverage Sprinklers

A complete line of UL Listed and FM Approved quick response extended coverage sprinklers for light hazard applications.

Horizontal Sidewall Sprinklers are approved for installation 4" - 12" (102mm - 305mm) below the ceiling.

Model F1FR QREC Sprinkler Types

- Extended Coverage Pendant
- Extended Coverage Horizontal Sidewall
 - EC-9 Deflector

Model F1FR QREC Recessed Sprinkler Types

- Recessed Extended Coverage Pendant
- Recessed Extended Coverage Horizontal Sidewall:
 - EC-9 Deflector

For Model F1FR QREC ½" K 5.6 (80) Sprinkler Types refer to Bulletin 028.

Approval Organizations

1. Underwriters' Laboratories, Inc. (UL)
2. Underwriters Laboratories of Canada (ULC)
3. Factory Mutual Approvals (FM)
4. NYC MEA 258-93-E

UL Listing Category

Sprinklers, Automatic & Open
Quick Response Extended Coverage Sprinkler

UL Guide Number

VNIV

Note: Consult appropriate FM Installation Standards regarding limitations of room size, ceiling height and minimum wall fire resistance rating.

Product Description

Reliable Models F1FR QREC and F1FR QREC Recessed Sprinklers are quick response sprinklers which combine the durability for a standard sprinkler with the attractive low profile of a decorative sprinkler.

The Models F1FR QREC and F1FR QREC Recessed Automatic Sprinklers utilize a 3.0mm frangible glass bulb. These sprinklers have demonstrated response times in laboratory tests which are five times faster than standard response sprinklers. This quick response enables these sprinklers to apply water to a fire faster than standard response sprinklers of the same temperature rating.



Extended Coverage
Pendant



Recessed Extended
Coverage Pendant

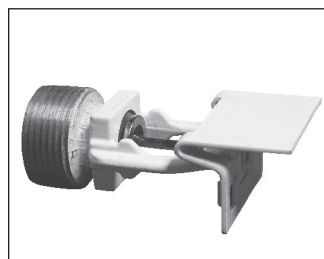

Extended Coverage
Horizontal Sidewall EC-9

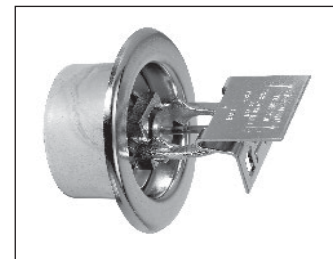

Recessed Extended
Coverage Horizontal Sidewall
EC-9

The glass bulb consists of an accurately controlled amount of special fluid hermetically sealed inside a precisely manufactured glass capsule. This glass bulb is specially constructed to provide fast thermal response. The balance of parts are made of brass, copper and beryllium nickel.

The temperature rating of the sprinkler is identified by the color of the glass bulb.

Application

Quick response sprinklers are used in fixed fire protection systems: Wet, Dry, Deluge or Preaction. Care must be exercised that the orifice size, temperature rating, deflector style and sprinkler type are in accordance with the latest published standards of the National Fire Protection Association or the approving authority having jurisdiction. Quick response sprinklers are intended for installation as specified in NFPA 13.

Model F1FR QREC Pendant Sprinkler

Deflector: EC

Installation Wrench: Model D Sprinkler Wrench or Model W2 Sprinkler Wrench

Approval Type: Quick Response Extended Coverage-Light Hazard Occupancy

Installation Data:

Nominal Orifice	Thread Size	Nominal K- Factor		Sprinkler Length	Temperature Rating	Approval Organizations	Sprinkler Identification Number (SIN)
		US	Metric				
$\frac{17}{32}$ " (20mm)	$\frac{3}{4}$ " NPT (R $\frac{3}{4}$)	8.0	115	2.2" (56.1mm)	135°F (57°C) 155°F (68°C)	1,2,3,4	R4842



Model F1FR QREC Recessed Pendant Sprinkler

Deflector: EC

Installation Wrench: Model GFR2 Sprinkler Wrench

Approval Type: Quick Response Extended Coverage-Light Hazard Occupancy

Installation Data:

Nominal Orifice	Thread Size	Nominal K-Factor		Sprinkler Length	Temperature Rating	Approval ⁽¹⁾ Organizations	Sprinkler Identification Number (SIN)
		US	Metric				
$\frac{17}{32}$ " (20mm)	$\frac{3}{4}$ " NPT (R $\frac{3}{4}$)	8.0	115	2.2" (56.1mm)	135°F (57°C) 155°F (68°C)	1, 2, 3, 4	R4842

⁽¹⁾ Refer to escutcheon data table for dimensions.

Model F1FR QREC Pendant and Recessed Pendant

Required Minimum Flow/Pressure		
Flow Rate gpm (L/min)	Pressure psi (bar)	Maximum Coverage Area Width x Length ft. x ft. (m x m)
26 (98.4)	10.6 (0,7)	16 x 16 (4.9 x 4.9)
33 (125.0)	17.0 (1,2)	18 x 18 (5.5 x 5.5)
40 (151.4)	25.0 (1,7)	20 x 20 (6.0 x 6.0) ⁽²⁾

⁽²⁾ UL/ULC Listed for both Pendant and Recessed Pendant at 135°F (57°C) only.

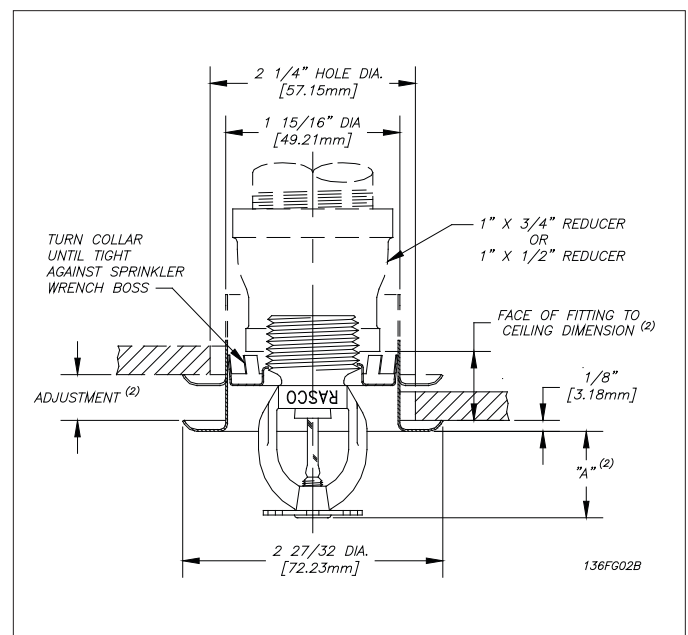

Model F1FR QREC Horizontal Sidewall Sprinkler

Deflector: EC-9

Installation Wrench: Model D Sprinkler Wrench of Model W2 Sprinkler Wrench

Approval Type: Quick Response Extended Coverage-Light Hazard Occupancy

Installation Data

Nominal Orifice	Thread Size	Nominal K-Factor		Sprinkler Length	Approval ⁽²⁾ Organizations	Temperature Rating	Sprinkler Identification Number (SIN)
		US	Metric				
17/32" (20mm)	3/4" NPT (R3/4)	8.0	115	2.85 (72.4mm)	1,2,3,4	135°F (57°C) 155°F (68°C) 175°F (79°C)	R4862

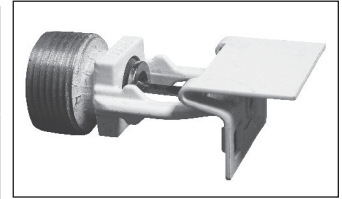

Model F1FR QREC Recessed Horizontal Sidewall Sprinkler

Deflector: EC-9

Installation Wrench: Model GFR2 Sprinkler Wrench

Approval Type: Quick Response Extended Coverage-Light Hazard Occupancy

Model F1FR QREC Horizontal Sidewall and Recessed Horizontal Sidewall

Required Minimum Flow/Pressure								
Flow Rate gpm (L/min)		Pressure psi (bar)		Maximum Coverage Area Width x Length ft. x ft. (m x m)	Temperature Rating ⁽¹⁾	Approval ⁽²⁾ Organizations		Deflector to Ceiling Dimension Min. - Max. Inches (mm)
UL	FM	UL	FM			F1	F2	
26 (98.4)	-	10.6 (0,7)	-	16 x 16 (4.9 x 4.9)	135°F (57°C)			6 - 12 (153 - 305)
29 (109.8)	32 (121.1)	13.1 (0,9)	16.0 (1,1)	16 x 16 (4.9 x 4.9)				4 - 12 (102 - 305)
29 (109.8)	36 (136.3)	13.1 (0,9)	20.2 (1,4)	16 x 18 (4.9 x 5.5)	155°F (68°C)	1, 2, 4	1, 2, 3, 4	4 - 12 (102 - 305)
32 (121.1)	40 (151.4)	16.0 (1,1)	25.0 (1,7)	16 x 20 (4.9 x 6.0)				4 - 12 (102 - 305)
36 (136.3)	44 (166.6)	20.2 (1,4)	30.2 (2,1)	16 x 22 (4.9 x 6.7)	175°F (79°C)			4 - 12 (102 - 305)
39 (147.6)	48 (181.7)	23.8 (1,6)	36.0 (2,5)	16 x 24 (4.9 x 7.3)				4 - 12 (102 - 305)
33 (124.9)		17.0 (1,2)		18 x 18 (5.5 x 5.5)	135°F (57°C)			4 - 12 (102 - 305)
39 (147.6)		23.8 (1,6)		14 x 26 (4.3 x 7.9)	135°F (57°C)			4 - 6 (102 - 153)
40 (151.4)		25.0 (1,7)		18 x 22 (5.5 x 6.7)	135°F (57°C)			4 - 12 (102 - 305)
46 (174.1)		33.1 (2,25)		14 x 26 (4.3 x 7.9)	135°F (57°C)	1, 2	1, 2	6 - 12 (153 - 305)
33 (124.9)		17.0 (1,2)		18 x 18 (5.5 x 5.5)	155°F (68°C)			4 - 12 (102 - 305)
40 (151.4)		25.0 (1,7)		18 x 22 (5.5 x 6.7)	155°F (68°C)			4 - 12 (102 - 305)
46 (174.1)		33.1 (2,25)		14 x 26 (4.3 x 7.9)	155°F (68°C)			6 - 12 (153 - 305)

⁽¹⁾ FM Approval of recessed sprinkler - 135°F (57°C) and 155°F (68°C) only.

⁽²⁾ Refer to escutcheon data table for dimensions.

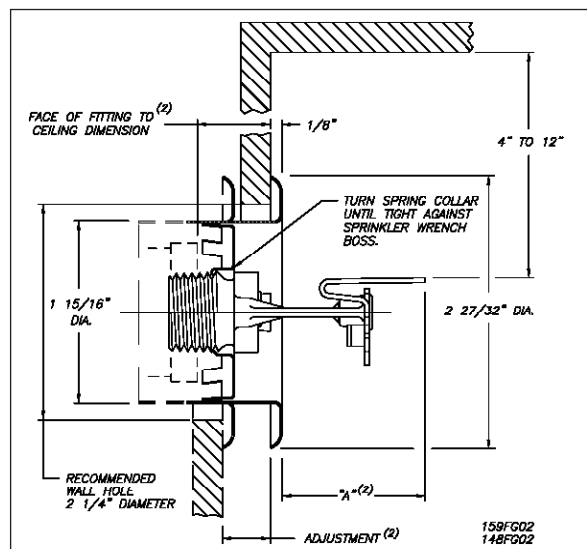

Installation

Quick response sprinkler are intended for installation as specified in NFPA 13. Quick response sprinklers and standard response sprinklers should not be intermixed.

The Model F1FR QREC Recessed Sprinklers are to be installed as shown. The Model F1 or F2 Escutcheons illustrated are the only recessed escutcheons to be used with the Model F1FR QREC Sprinklers. The use of any other recessed escutcheon will void all approvals and negate all warranties.

When installing Model F1FR QREC Sprinklers, use the Model D Sprinkler Wrench or Model W2 Sprinkler Wrench. When installing Model F1FR QREC Recessed Pendent or Recessed Sidewall Sprinklers, use the Model GFR1 Sprinkler Wrench. Any other type of wrench may damage these sprinklers.

Glass bulb sprinklers have orange bulb protectors to minimize bulb damage during shipping, handling and installation. REMOVE THIS PROTECTION AT THE TIME THE SPRINKLER SYSTEM IS PLACED IN SERVICE FOR FIRE PROTECTION. Removal of the protectors before this time may leave the bulb vulnerable to damage. RASCO wrenches are designed to install sprinklers when covers are in place. REMOVE PROTECTORS BY UNDOING THE CLASP BY HAND. DO NOT USE TOOLS TO REMOVE THE PROTECTORS.

Maintenance

The Models F1FR QREC and F1FR QREC Recessed Sprinklers should be inspected and the sprinkler system maintained in accordance with NFPA 25. Do not clean sprinklers with soap and water, ammonia or any other cleaning fluids. Remove dust by gentle vacuuming. Replace any sprinkler which has been painted (other than factory applied) or damaged in any way. A stock of spare sprinklers should be maintained to allow quick replacement of damaged or operated sprinklers. Prior to installation, sprinklers should be maintained in the original cartons and packaging until used to minimize the potential for damage to sprinklers that would cause improper operation or non-operation.

Temperature Ratings

Classification	Sprinkler Rating		Maximum Ambient Temp.		Bulb Color
	°F	°C	°F	°C	
Ordinary	135	57	100	38	Orange
Ordinary	155	68	100	38	Red
Intermediate	175	79	150	66	Yellow

Maximum Working Pressure

175 psi (12 bar)

SIN R4842 & R4862 cULus listed for 250 psi (17 bar)

100% Factory tested hydrostatically to 500 psi (34.5 bar)

The equipment presented in this bulletin is to be installed in accordance with the latest published Standards of the National Fire Protection Association, Factory Mutual Research Corporation, or other similar organizations and also with the provisions of governmental codes or ordinances whenever applicable.

Products manufactured and distributed by Reliable have been protecting life and property for almost 100 years.

Manufactured by



Reliable Automatic Sprinkler Co., Inc.

(800) 431-1588

(800) 848-6051

(914) 829-2042

www.reliablesprinkler.com

Sales Offices

Sales Fax

Corporate Offices

Internet Address



Recycled Paper

Revision lines indicate updated or new data.

EG. Printed in U.S.A. 03/17 P/N 9999970142

Sprinkler Types

Extended Coverage Pendent

Extended Coverage Sidewall

- EC-9 HSW Deflector

Recessed Extended Coverage Pendent

Recessed Extended Coverage Sidewall

- EC-9 HSW Deflector

Finishes⁽¹⁾

Standard Finishes ⁽¹⁾	
Sprinkler	Escutcheon
Bronze	Brass
Chrome	Chrome
White & Black Polyester ⁽³⁾	White
Special Application Finishes	
Sprinkler ⁽²⁾	Escutcheon
Electroless Nickel PTFE ⁽³⁾	Electroless Nickel PTFE
Bright Brass	Bright Brass
Black Plating	Black Plating
Black Paint	Black Paint
Off White Satin	Off White
Chrome	Chrome Dull

⁽¹⁾ Other colors and finishes are available on special order. Consult factory for details.

⁽²⁾ FM Approval limited to bronze, bright and satin chrome plated, and polyester coated only.

⁽³⁾ cULus Listed Corrosion Resistant Sprinkler

Escutcheon Data

Escutcheon Model	Adjustment	"A" Dimension	Face of Fitting to Ceiling or Wall Dimension
F1	3/4" (19mm)	3/4" (19mm) ⁽¹⁾ 1 3/8" (35mm) ⁽²⁾	3/16" (5mm) - 15/16" (24mm)
F2	1/2" (13mm)	1" (25mm) ⁽¹⁾ 1 9/16" (40mm) ⁽²⁾	3/16" (5mm) - 1 1/16" (18mm)

⁽¹⁾ EC Pendent

⁽²⁾ EC HSW

Ordering Information

Specify:

1. Sprinkler Model: F1FR QREC
2. Sprinkler Type
3. Temperature Rating
4. Sprinkler Finish
5. Thread Type: [3/4" NPT] [ISO 7-1R3/4]
6. Escutcheon Type
7. Escutcheon Finish (where applicable)

Note: When Model F1FR Recessed sprinklers are ordered, the sprinklers and escutcheons are packaged separately.